

QUALITY RANGE COLLARED EYEBOLTS

METRIC COARSE THREAD - TO BS 4278 TABLE 1 -1984

TESTED AND CERTIFIED

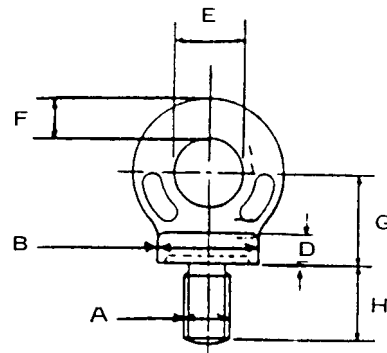

VERTICAL SWL TONNES	A mm	B mm	D mm	E mm	F mm	G mm	H mm	WEIGHT EACH KGS
*0.10	6	22	7	15	9	20	18	0.06
*0.15	8	22	7	15	9	20	18	0.06
*0.25	10	22	7	15	9	20	18	0.06
0.40	12	22	7	15	9	20	18	0.06
*0.50	14	29	10	20	12	26	23	0.15
0.80	16	29	10	20	12	26	23	0.15
*1.00	18	36	12	24	14	32	28	0.27
1.60	20	40	14	27	16	36	32	0.38
*1.60	22	45	14	30	17	40	35	0.54
2.50	24	52	17	35	21	46	40	0.85
*2.50	27	58	20	39	23	52	46	1.13
4.00	30	65	22	44	26	58	51	1.62
*4.00	33	72	24	48	29	64	56	2.37
6.30	36	81	27	54	32	72	63	3.12
*6.30	39	86	29	57	33	76	67	3.81
8.00	42	101	34	68	40	90	79	6.27
*8.00	45	101	34	68	40	90	79	6.45
*10.00	48	101	34	68	40	90	79	6.51
12.50	52	115	38	76	46	102	89	9.58
16.00	56	128	43	86	51	114	100	12.99
20.00	64	144	48	96	58	128	112	18.20

SIZES MARKED* ARE ADDITIONAL AND PROPORTIONAL TO THE SPECIFICATION.