

QUALITY RANGE DYNAMO EYEBOLTS

METRIC COARSE THREAD - TO BS 4278 TABLE 3 - 1984

TESTED AND CERTIFIED

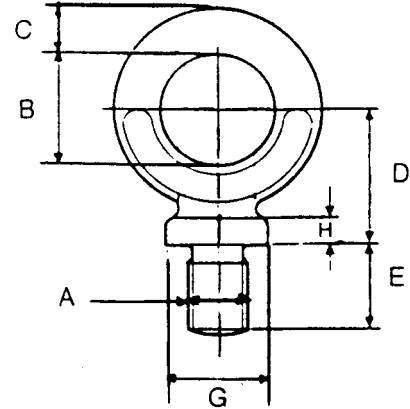

VERTICAL SWL TONNES	A mm	B mm	C mm	D mm	E mm	G mm	H mm	WEIGHT EACH KGS
*0.10	6	22	9	27	18	17	5	0.07
*0.15	8	22	9	27	18	17	5	0.07
*0.25	10	22	9	27	18	17	5	0.07
0.32	12	22	9	27	18	17	5	0.07
*0.50	14	32	13	41	28	29	9	0.24
0.63	16	29	11	34	23	23	6	0.14
*1.00	18	40	15	47	32	32	9	0.40
1.25	20	40	15	47	32	32	9	0.40
*1.60	22	44	17	53	35	35	14	0.61
2.00	24	51	19	60	40	40	12	0.80
3.20	30	64	24	76	51	51	14	1.72

SIZES MARKED * ARE ADDITIONAL AND PROPORTIONAL TO THE SPECIFICATION